

New & Used Machinery For The Fastener & Wire Industry

Your Guide to Sensible Machinery Solutions.



Barbarotto Int'l Machinery

Oceanside, New York

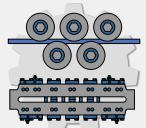
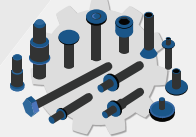
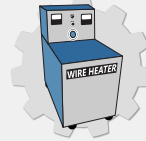
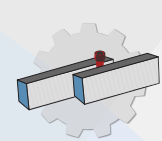
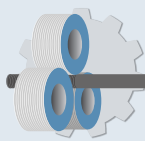
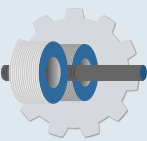
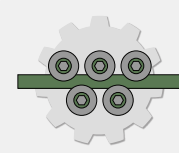
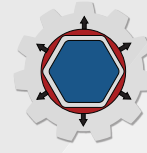
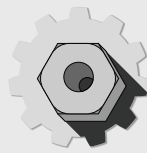
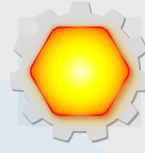
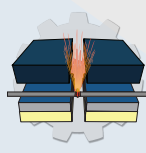
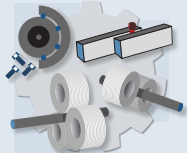
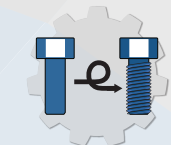

Modular Machinery For
the Wire & Fastener Industries.
Automation and combining
operations is our specialty.



Multi-Station Cold and Warm
Forming Machines for
Fasteners & Special Parts.



Weigh / Count Solutions
For a Wide Variety of
Packaging Needs.
High Speed Counting Units.



Drawing Technology Inc.
In-Line Wire Drawing & Handling



2 Die & 3 Die
Cylindrical
Thread Rollers



CHI NING
Since 1981
Nut & Parts Formers

New Equipment



BarbarottoMachinery.com

1-888-988-8733

Used Equipment



Used Machinery Sales



Cylindrical Threader



Fenn Bar Shear



Landis Thread Cutter



Sacma Progressive CF



WF Rod Header



National Boltmaker



National 2 Die 3 Blow



National Cold Former



Wire Straighten & Cutoff



WF Thread Roller

Used Equipment



Bar Shears

Bar Straightener

Bolt Trimmers

Cold Heading & Cold Forming

- Boltmakers
- 1 Die 1 Blow
- 1 Die 2 Blow
- 2 Die 2 Blow
- 2 Die 3 Blow
- 2 Die 4 Blow
- Nail Headers
- Open Die
- Progressive & Multi-Station Cold Formers
- Rod Headers
- Semi Tubular, Full Tubular & Rivet Headers

Centerless Grinders

Hot Forge

- Upsetters
- Presses
- Parts Forming

Inspection Equipment

Lathes

Material Handling & Feeding

Miscellaneous

Nail Equipment

Nut Formers, Nut Tappers & Nut Slotters

- Nut Formers
- Nut Tappers
- Nut Slotters

Packaging Equipment

- Vertical Bagging Machine
- Form, Fill & Seal

Point Forming, Cutting & Chamfering

- Forming (Pinch & Forging)
- Cutting (Rotary Head)
- Chamfering

Presses

- Hobbing

Shavers

Slotters

- Drillers
- Head Slotters
- Shank Slotters

Swagers

Thread Cutting

Thread Rolling

- Cylindrical 2 Die
- Cylindrical 3 Die, 4 Die
- Flat Die
- Planetary for Headed Fasteners
- Planetary for Studs & Rods (Headless)
- Vertically or Side Mounted

Tool Room Equipment

- Surface Grinders

Wire Butt Welders

Wire Coiling / Spring Coiling

Wire Benders

Wire Drawing

- Multi-Draft
- Bull Blocks
- In-Line

Wire Descaling

Wire Forming

- 4-Slides
- Other

Wire Heaters

Wire Passive Turntables

Wire Roll Pointer

Wire Straighten & Cut



Hilgeland Pointer PN4



Waterbury Hand Feed Threader

CHECK OUT OUR WEBSITE FOR CURRENT LISTINGS!

BarbarottoMachinery.com

Liquidations

Barbarotto Machinery offers unmatched results in assuring that your surplus equipment is successfully marketed.

On-going Liquidations insure that your assets are not sold below market value, which is often a reality at an auction. Backed by over 30 years of experience in the Wire and Fastener Industries, Barbarotto Machinery offers unmatched results in assuring that your surplus equipment is successfully marketed in a timely fashion. Our #1 Priority is to maximize your return. Whether you have just one machine or an entire plant, detail is taken to assure the best possible results. Our **Liquidation services** include everything from inventorying the equipment and tooling, market research, advertising, quoting, negotiating the sale, and collecting of the funds.

When you put your assets in our hands you are assured of the best possible results.

Partial Plant Liquidations often allow the manufacturer to obtain cash from unused machinery so that they can continue operating. Complete Plant Liquidations can include a Guaranteed Buy-out after a agreed upon period of time. We also accept your unwanted machinery on consignment where we can clean, paint and repair tired machinery to increase its value.

Auctions

Serving the Wire and Fasteners Industry exclusively, Barbarotto Machinery offers complete, fair and honest Auction experience.

Disposing of small lots of equipment or complete facilities, we treat each sale with the understanding that years of hard work and investment went into obtaining your assets.

Starting with a fair appraisal, we then offer several options which include:

1. A Commission Sale which results in all proceeds from sale (less the direct expenses) going to the owner. Our Commission is paid by the Buyers Premium that is charged over and above the actual bid.
2. A Guaranteed Minimum Return, with an agreed upon split of the additional proceeds.
3. A Cash Buy-out. We buy your machinery and take all the risk at the sale.

TALK TO US FOR IDEAS TO PRESERVE YOUR ASSETS.



We Represent the Finest in New Machinery

Videx has been represented here in North America by Barbarotto Machinery for over 30 years.



The Videx Name Means Innovation!

All Videx systems are modular and we can combine operations to better serve our customers.

If you can think of it, we can build it. Automation and combining operations is our specialty.



VA High Speed Dual Spindle Thread Rollers

Features 2 Individual Adjustable Rolling Stations

- Thread 2 Diameters
- Thread & Knurl
- Straighten & Thread



Wire Forming Automatic & Semi-Auto

- Straighten
- Cut Off Blank
- Cold Heading
- Chamfer
- Thread
- Form Roll
- Groove
- Bend to Finished Product

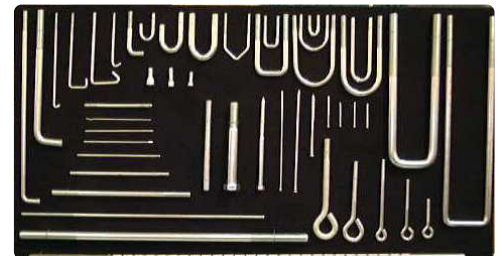

Any & All Combinations, Easy Set Up!

Rod Heading & Extruding

- Diameters up to 2"
- Extrusion length up to 8"
- Long bars up to 30'
- Hand Feed / Magazine Feed



Straighten & Cut-Off Quick Change Models

- Less Tool Expense Per Diameter
 - High Speed - Up to 350 FPM
 - Up to 600 Cuts Per Minute
- 8 Standard Models - Up to 1-1/4"

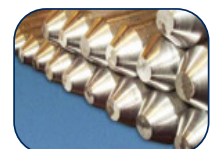



Impact Cutters or Bar Shears

Crop straight bars to precise lengths with a square cut off face.

- Cut off length repeatability $\pm 0.003''$ by hitting a positive stop.
- Bar is supported during shearing, assuring square cut off face.
- Compact Design
- Quick Change over on diameters and lengths.



Chamfering Machine For Round Bars

- Diameter range .187" to 3".
- Unlimited lengths example 4" to 30'
- Stamping on single or double end
- Attached to any Straighten and Cut machine
- Can perform two different operations on each end.

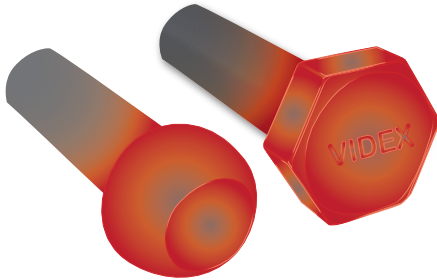

Solid Die Hot Forge Machines

- 300 Ton to 500 Ton Model
- Both Fully Automatic & Semi-Automatic Machines Use Magazines (For Easy Handling)

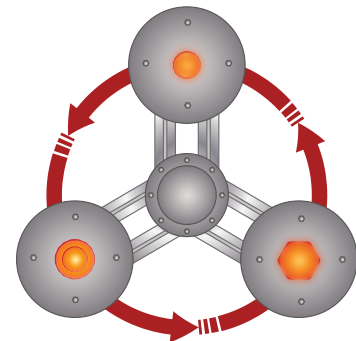
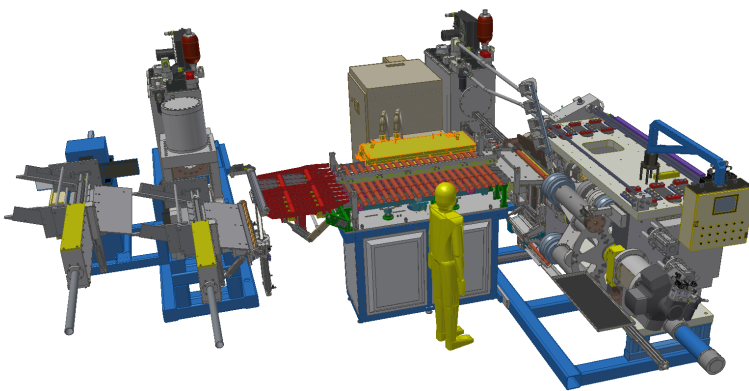
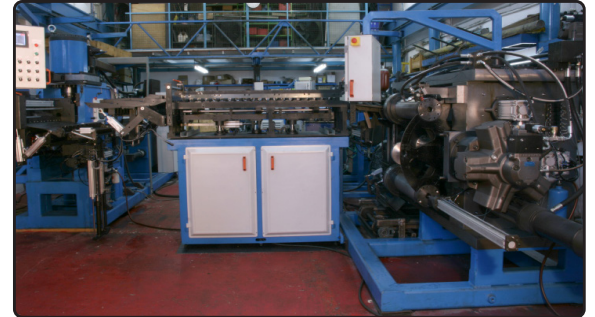
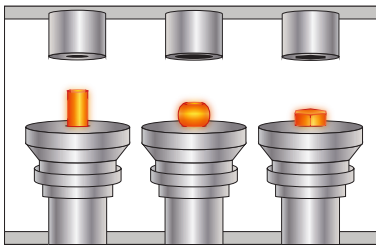

WE OFFER

**Thread Rolling Dies
Planetary & Flat Die**

Videx Machinery



Nedschroef Machinery

Specialized in Metal Forming.



Nedschroef Machinery is a leading manufacturer of cold and warm metal forming machines.

Their high-performance machines allow mass production of fasteners and parts.

Nedschroef's goal is to provide the highest quality equipment and solutions to improve our customer's performance.

Headers

- **Nedbase:** Compact, high-speed machine with an excellent price-quality ratio
- **Nedform:** Machine with modular design, client-specific expansion options, hi-tech components and demand-oriented automation solutions.
- **Nedform Hybrid:** New forming capabilities and high productivity
- **Nedmax:** Machine for large-diameter parts.
- **NC714:** Makes forming easier and efficient

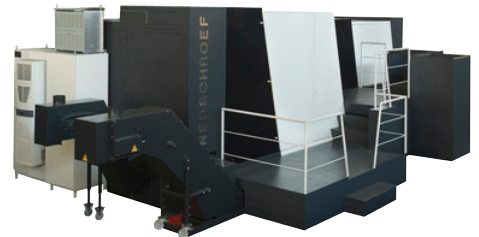

Boltmakers

- **Nedbase Boltmaker:** economic machine producing bolts in one operation.
- **Nedform Boltmaker:** Producing bolts in one operation.

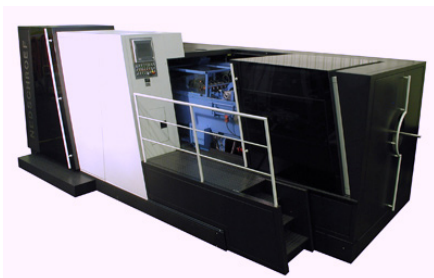

Hot Nut Former MW

High Productivity & Cost-Efficiency

This high capacity hot nut former is suitable for forming nuts from M14 up to M42 with a maximum width across flats of 33 to 65 mm.

The hot nut former requires a low investment and is designed for a very cost efficient production of all kinds of nuts.

Benefits:

- Durable design
- Short set-up times
- Consistent product output and long lifetime of tooling
- Compact design
- High capacity and high productivity
- Operator friendly and easy maintenance



Straightening Machine RRA

High Productivity and Cost-efficiency

Straightening machine RRA straightens axially symmetric parts like long axles, shafts, bolts, screws and rods. Straightening improvement is up to factor 10.

The machine is suitable for the following product shapes: with or without thread, with flange in the middle, with stepped shafts and with threaded ends.

Benefits:

- High output
- Short set-up times
- Fault signalization: automatic rejection of defect parts
- Easy reproducibility of proven settings
- Compact design
- Operator friendly and easy maintenance



Nedshear

High-speed Impact Cutting

The Nedshear high-speed impact cutting machine produces blanks from coiled wire.

The high-precision linear wire feeding system with servo direct drive makes this machine very accurate.

Benefits:

- Accurate cut-off length
- High shearing speed
- Fully automatic
- Length corrections possible during running

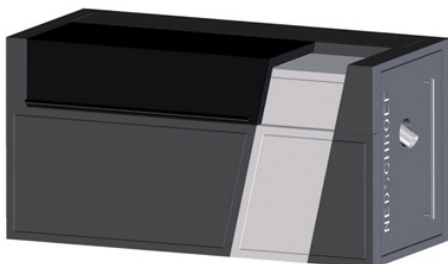

Nedschroef
Machinery



PMC - 2-Die & 3-Die Thread Rollers



SINCE 1976

Guaranteed Performance.

Barbarotto Machinery is pleased to offer
PMC Thread Rolling to the North American market!

In-Feed / Thru-Feed Hydraulic Thread Rollers 2-Die & 3-Die Models



2 Die Series - 160 Ton



- Proven Technology, producing Quality Threaded Parts
- Sturdy, Durable, High Quality Construction
- Sensible Price Structure
- Technical Support and Training here in the USA
- High Quality Thread Rolling Dies

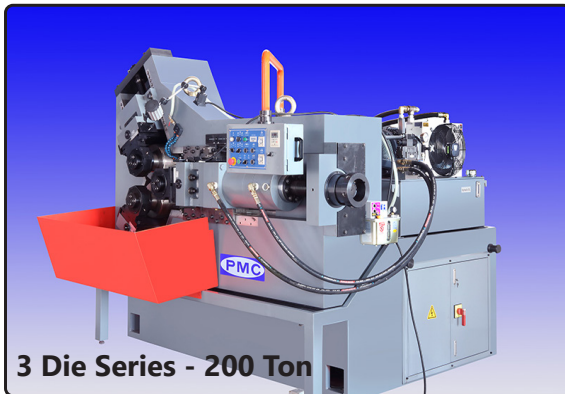

3 Die Series - 200 Ton

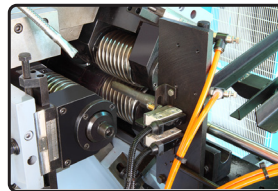

Capacity Range: Models available up to **250,000 lbs.** of rolling pressure.

Suitable for Wide Range of Roll Forming Threads, including:
Long Screws, Shafts, Scaffolds, Hardware, Bicycle, Automotive,
Construction, etc...

Hydraulic Bar & Shaft Straightening Machine

Heavy-Duty High-Grade Machines for In-Feed & Thru-Feed Precision Straightening

4 Models Available: Covering range from
5mm Bar Dia. up to 95mm Bar Dia.

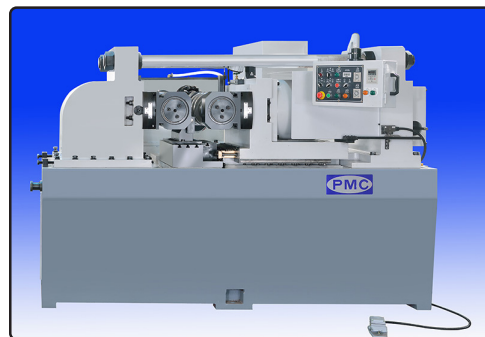

- Capacity 95 mm bar diameter (w/out heat treatment) and 75 mm shaft diameter (with heat treatment)
- 130 mm very heavy duty spindle diameter.
- 300 - 350 mm roll straightening dies diameter X die-width up to 600 mm (max.)
- Machine equipped with one set of Concave & Convex dies for Thru-Feed straightening or special made dies for In-feed roll Straightening
- Suitable for roll straightening a variety of parts.



PMC Machinery



Chi Ning Nut & Cold Formers



CHI NING
Since 1981

New Chi Ning Nut Formers are Affordable, High-Tech solution for revitalizing The American Nut Industry!

With Over 30 Years of Experience building top quality Cold Formers and Tools!



Capacity: Up to 1¼" Cold, 2" Cut-Off Diameter



**Cold Formers
&
High Speed Nut Formers**



NUT TAPPING MACHINES

FTM MODELS, FNF MODELS, FRN MODELS ADVANTAGES

- STEADY FEEDING OF MATERIAL BY AIR PRESSURE.
- EASY ADJUSTMENT AND MAINTENANCE OF BELTS.
- RAISES 30% - 40% LIFETIME OF TAP THAN CONVENTIONAL TAP.
- HIGHER EFFICIENCY, EASY TO CHANGE TAP AND CAN WORK SEPARATELY BY SINGLE SHAFT.
- STOP FEEDING WHEN TAP IS BLUNT OR BAD BORE DIAMETER.
- AIR PRESSURE CYLINDER PULLS BACK AUTOMATICALLY TO READY POSITION WHILE DETECTING ABNORMAL OPERATION.
- EASY TO CHANGE THE SPEED OF TAPPING BY USING OUR AIR PRESSURE CYLINDER.
- ECONOMICALLY SAVE MORE POWER AND LESS SPACE REQUIREMENT.



Chi Ning
Machinery



Fastener Packaging Systems

Enhance Your Packaging Department with 2018 Technology.

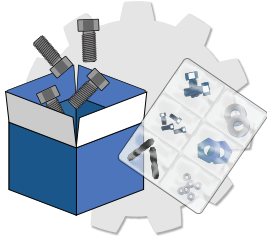

Bonotto packaging

Owner has over 45 years
experience in packaging
and counting.

Whether you package in boxes or bags, Bonotto Packaging can provide assorted
Weigh / Count solutions for a wide variety of packaging needs.

We Can Think Big or Small...

Kit Packing Solutions

Master Scale Solutions



**High Speed
Counters**



**Cell Pack
Bagger**



**Low Profile
Bagger**

**Ideal For
Distributors**



**Quick Change
Scale**



BP-310

**Low Profile 1/4 Keg with
Inspection Station**



BP-306 High Speed Master Scale



**BP-102/104 VFFS Machine
Master Scale & Bagger**



Carton Erectors

Bonotto Packaging

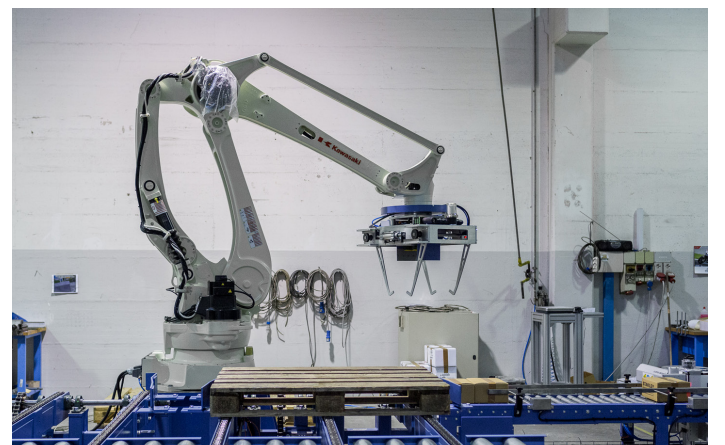

Robotic Palletizing Systems

The Finest In Wire Drawing Machinery & Accessories



Drawing Technology Inc.



DTI In-Line Wire Drawing equipment and related Accessories are built by the most experienced team in the industry.

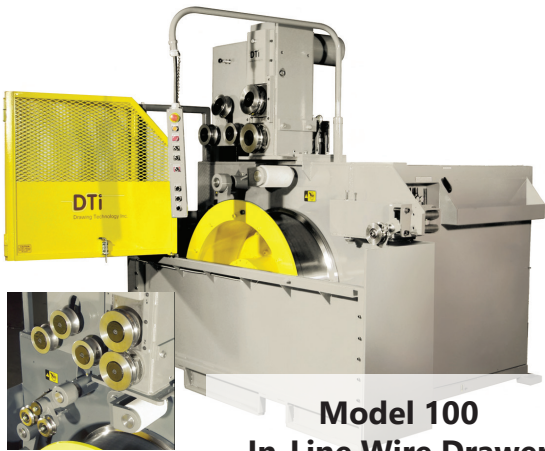

**Model 100
In-Line Wire Drawer**

**Power Turntable
Up To 5,000 lbs**



**Rod Flipper
[Z or S Types]**

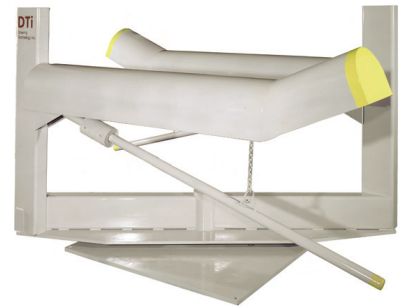

**Model 43
In-Line Wire Drawer**

**Power Driven Uncoiler
For Large Diameter Applications**



**Descaling Drawing and
Recoiling**



Power Feed & Straighteners

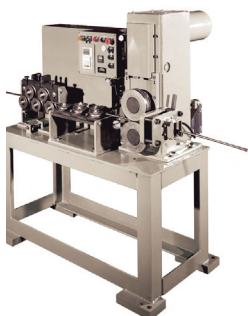

**Mechanical Descaler
For Hot Rolled Rod**

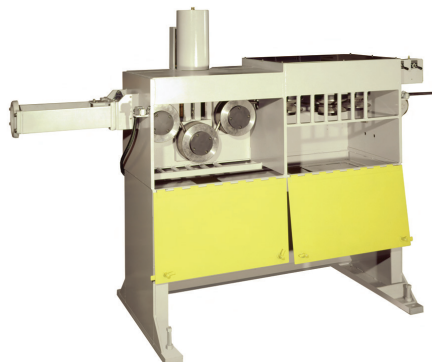

**We Also:
Remanufacture or Repair
(All Makes & Models)**

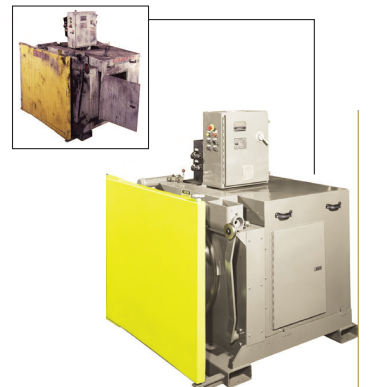

Featured Machinery



**5/8" National Boltmaker
3-Die 4-Station
Ref. No. 26673**

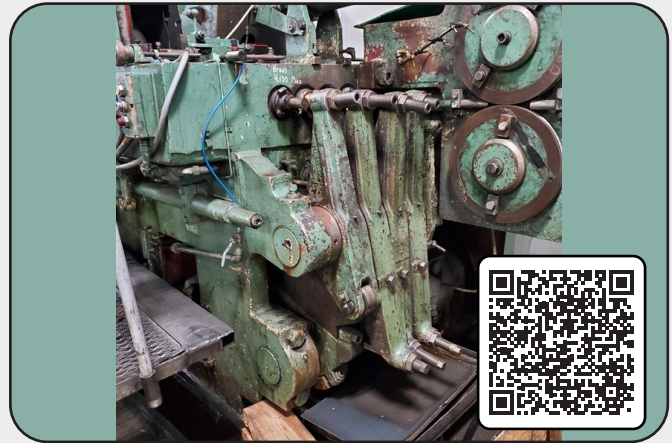

**1/2" National Long Stroke
4-Die 5-Station
Ref. No. 26435**



**3/4" Peltzer & Ehlers Model
GB-20-4 4D 5 Prog. Header
Ref. No. 25296**

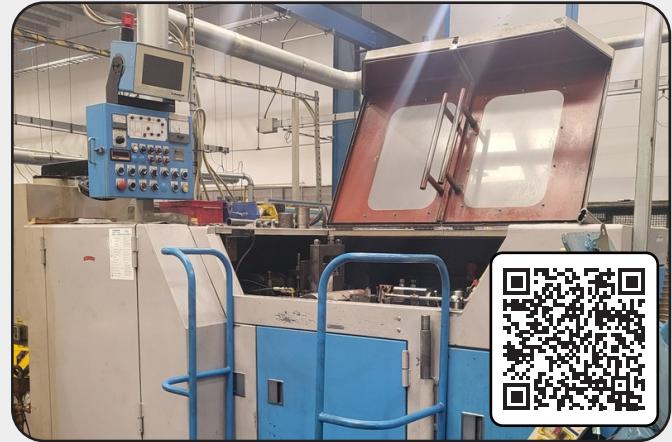

**3/8" Asahi Okuma
AOS-10-15 2 Die 2 Blow
Ref. No. 26691**



**3/8" Asahi Okuma
AOS-10B (RF) 2 Die 2 Blow
Ref. No. 26691**

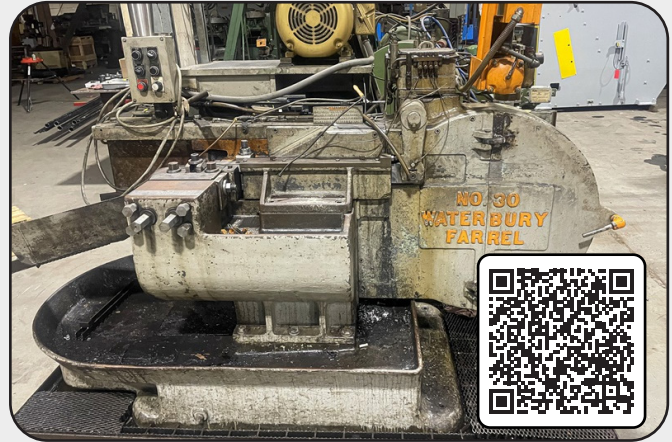

**1/2" No. 30 Waterbury
Horizontal Hand Feed
Ref. No. 26674**

Featured Machinery

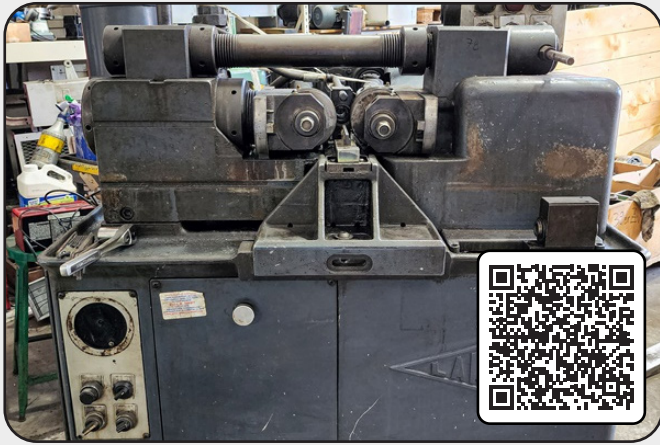

**1-1/2" Landis Lan-nu-rol
In-feed Thru-Feed
Ref. No. 26499**



**4" Bolt - 6" Pipe Kenco 6-4
Thread Cutter w/ Lead Screw
Ref. No. 26614**

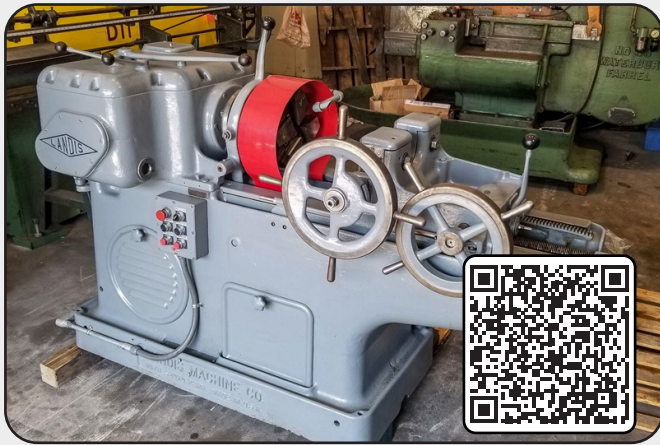

**2" Landis Single Spindle
with Lead Screw
Ref. No. 25550**

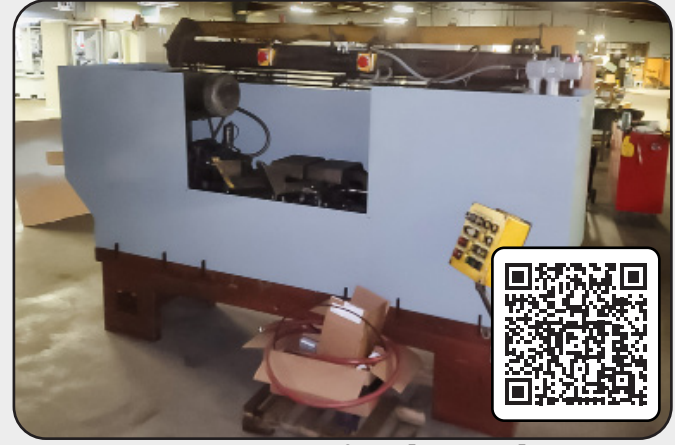

**1-1/4" Haise Single End or
Double End Chamfer
Ref. No. 26527**

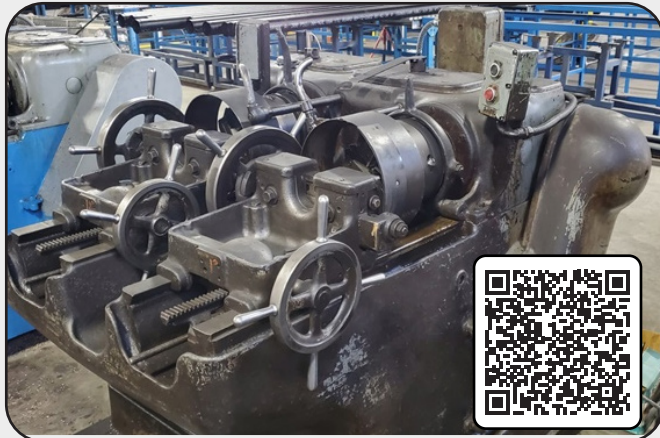

**1-1/2" Landis Double
Spindle Thread Cutter
Ref. No. 26615**



**Eurobend Mesh Welding Line
Video Upon Request
Ref. No. 26675**

Featured Machinery



Machine Engineering NA

Available Year End

**1/2" Fully Automatic
U-Bolt Machine
Adjustable Bending Die
Model VAS-20-DBQ**



In-Stock New Machinery

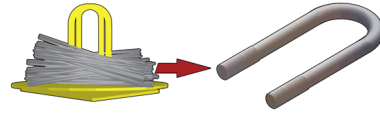

Available April 2024

**5/8" Fully Automatic
U-Bolt Machine
Adjustable Bending Die
Model VAS-25-DBQ**



**300 Ton
Etchells Forging Press
Ref. No. 26532**



**125 Ton
Etchells Forging Press
Ref. No. 26531**

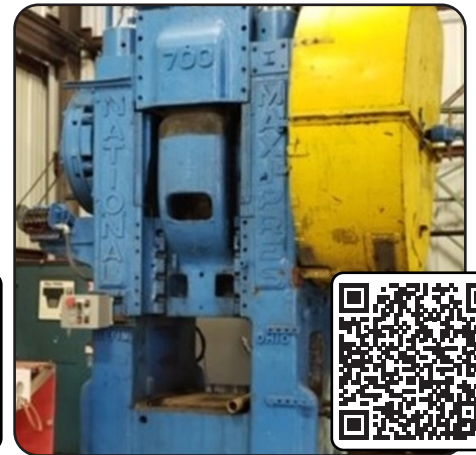

**700 Ton National
Maxi-Press Cell
Ref. No. 26126**



**3" National High-Duty
Upsetter
Ref. No. 26447**

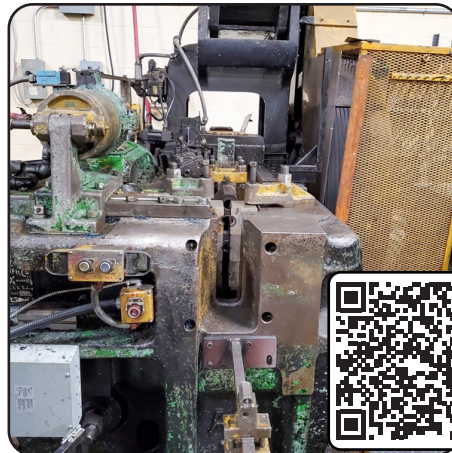

**1-1/2" AJAX Upsetter
w/ Air Clutch
Ref. No. 26609**



**1" Hill Acme
Upsetter
Ref. No. 26146**

Featured Machinery



**1/2" Shuster 3AV
Wire Straighten and Cut
Ref. No. 26594**



**3/8" Lewis Model 8C
Wire Straightener and Cutoff
Ref. No. 26617**

USED PACKING EQUIPMENT

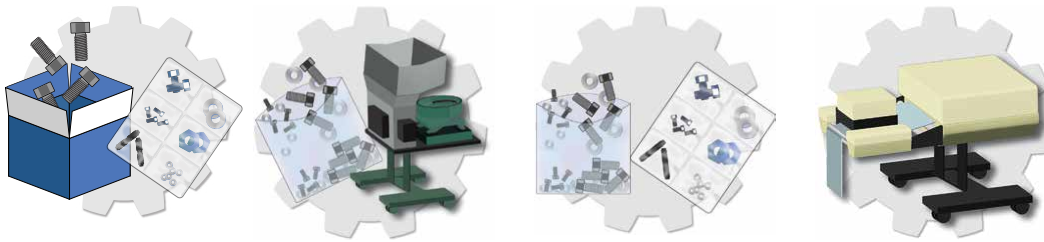

- **Bonotto Packaging**
- **Autobag Portable Bagging Units**
- **Batching Systems**



COMPLETE KIT PACKING DEPARTMENT

- **Counters**
- **Scales**
- **Bagging**
- **Pre-Feed Equipment**

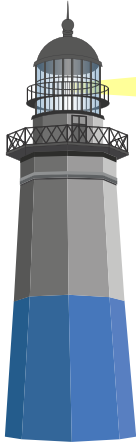

Your Guide to Sensible Machinery Solutions.

Barbarotto Int'l Machinery

Oceanside, New York

Fastener, Wire & Packaging Equipment Since 1981

Your Guide to Sensible Machinery Solutions.



Ben Barbarotto

ben@barbarottomachinery.com

Videx Sales & Service

www.BarbarottoMachinery.com

Office: 516.594.1300 | Cell: 516.659.9805

3311 Royal Ave., Oceanside, New York 11572-3625 USA



Fastener, Wire & Packaging Equipment Since 1981

Your Guide to Sensible Machinery Solutions.



Fred Barbarotto

fred@barbarottomachinery.com

President

www.BarbarottoMachinery.com

Office: 516.594.1300 | Cell: 516.946.9056

3311 Royal Ave., Oceanside, New York 11572-3625 USA



SCAN CODE
TO ADD
CONTACT INFO

Fastener, Wire & Packaging Equipment Since 1981

Your Guide to Sensible Machinery Solutions.

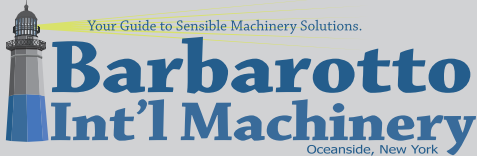

Carl Barbarotto

Carl.Barbarotto@rcn.com

Used Machinery Sales

www.BarbarottoMachinery.com

Office: 202.966.3573

3311 Royal Ave., Oceanside, New York 11572-3625 USA



Fastener, Wire & Packaging Equipment Since 1981

Your Guide to Sensible Machinery Solutions.

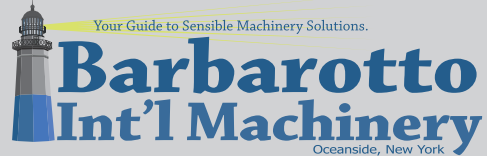

Lori Scheinman

lori@barbarottomachinery.com

Packaging Sales & Support

www.BarbarottoMachinery.com

Office: 516.594.1300

3311 Royal Ave., Oceanside, New York 11572-3625 USA

